

Outline

1. Introduction to JDBC
2. Accessing a database: practical steps
3. Prepared statements
4. Design patterns (DAO)
5. Connection pooling



<http://dilbert.com/strips/comic/1995-11-17/>

Goals

- ▶ **Enable Java applications to access data stored in Relational Data Bases**
 - ▶ Query existing data
 - ▶ Modify existing data
 - ▶ Insert new data
- ▶ **Data can be used by**
 - ▶ The algorithms running in the application
 - ▶ The user, through the user interface

Goals (for Web Applications)

- ▶ Access SQL DBMS's from JSP pages
 - ▶ JDBC technology
- ▶ Integrate SQL query results into the resulting HTML content
- ▶ Generate SQL queries according to FORM values

Goals (for GUI Applications)

- ▶ Access SQL DBMS's from the JavaFX application
 - ▶ JDBC technology
- ▶ Load 'massive' data directly from database
- ▶ Query 'on-demand' information from database
- ▶ Store computation results

JDBC

- ▶ Standard library for accessing relational databases
- ▶ Compatible with most/all different databases
- ▶ JDBC : Java Database Connectivity
- ▶ Defined in package `java.sql` and `javax.sql`
- ▶ Documentation:
 - ▶ <http://www.oracle.com/technetwork/java/javase/tech/database-137795.html>
 - ▶ JDBC Overview:
<http://www.oracle.com/technetwork/java/overview-141217.html>

JDBC scope

- ▶ **Standardizes**
 - ▶ Mechanism for connecting to DBMSs
 - ▶ Syntax for sending queries
 - ▶ Structure representing the results
- ▶ **Does not standardize**
 - ▶ SQL syntax: dialects, variants, extensions, ...

Architecture

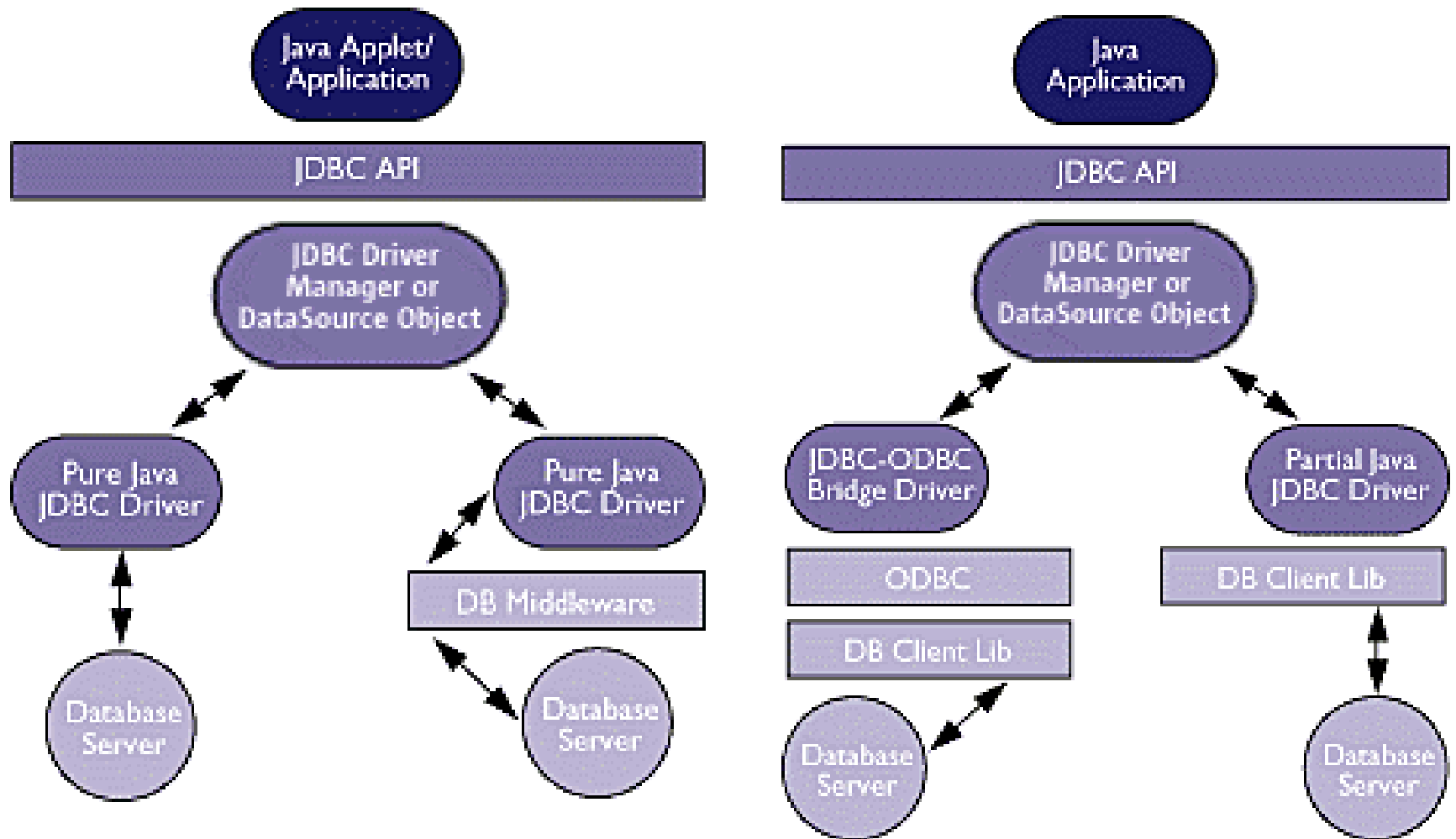

Architecture

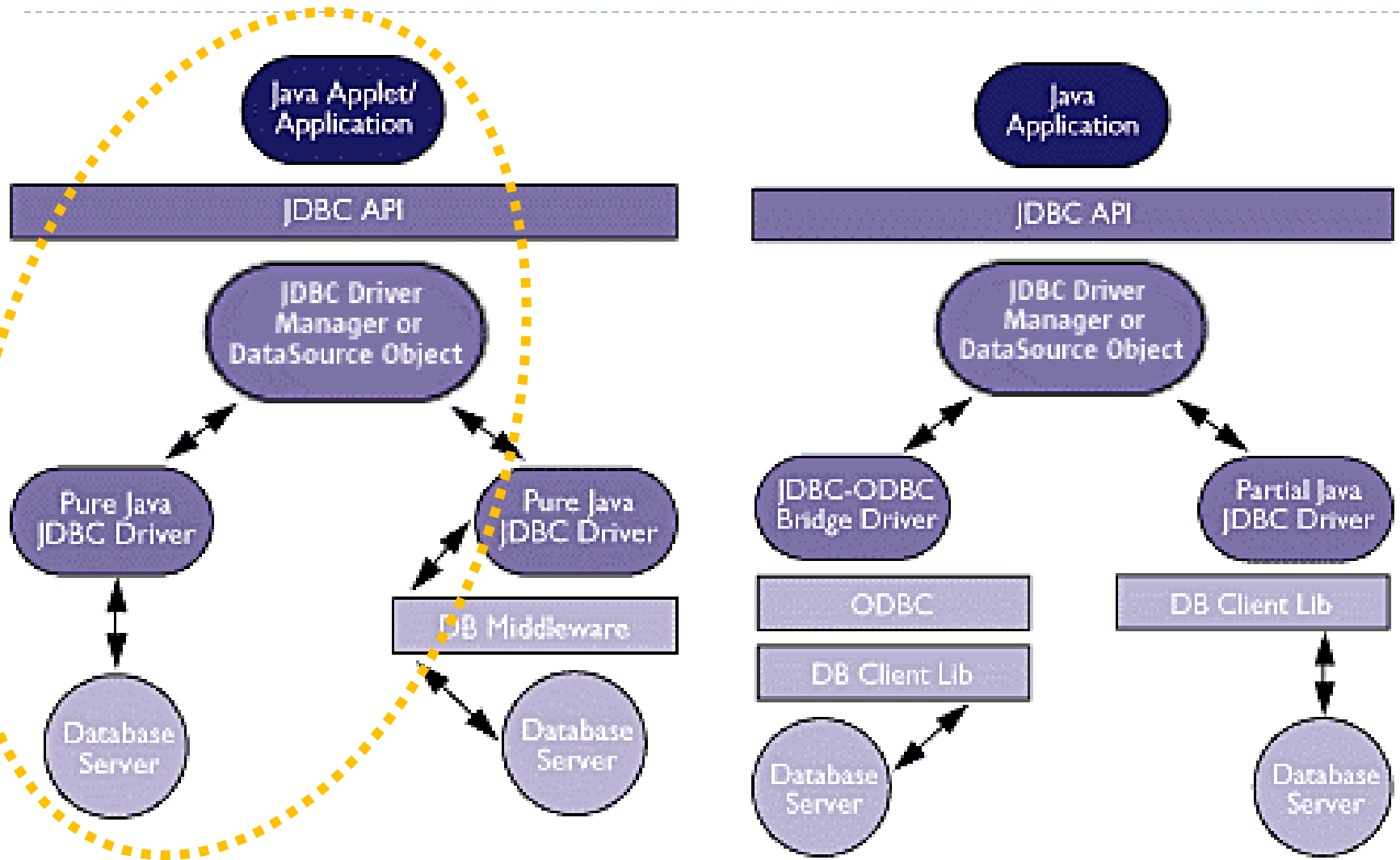

Main elements

- ▶ Java application (in our case, JSP or JavaFX)
- ▶ JDBC Driver Manager
 - ▶ For loading the JDBC Driver
- ▶ JDBC Driver
 - ▶ From DBMS vendor
- ▶ DBMS
 - ▶ In our case, MySQL

Basic steps

1. Load the JDBC driver
2. Define the connection URL
3. Establish the connection
4. Create a statement object
5. Execute a query or update
6. Process the results
7. Close the connection

1. Loading the driver

- ▶ A Driver is a DMBS-vendor provided class, that must be available to the Java application
 - ▶ In general: Should reside in Project's libraries
 - ▶ For JSP: Must reside in Tomcat's CLASSPATH
- ▶ The application usually doesn't know the driver class name until run-time (to ease the migration to other DMBSs)
- ▶ Needs to find and load the class at run-time
 - ▶ `Class.forName` method in the Java Class Loader (not needed in recent versions)

MySQL JDBC driver

- ▶ **MySQL Connector/J**
 - ▶ <http://dev.mysql.com/downloads/connector/j/>
 - ▶ Provides mysql-connector-java-[version]-bin.jar
 - ▶ Copy into CLASSPATH
 - ▶ E.g.: c:\Program files\...\jre...\lib\ext
 - ▶ Copy into project libraries
 - ▶ Copy into Tomcat's libraries
- ▶ **The driver is in class**
 - ▶ `com.mysql.jdbc.Driver`

Loading the MySQL driver

```
import java.sql.Connection;
import java.sql.DriverManager;
import java.sql.SQLException;

// Notice, do not import com.mysql.jdbc.* or you will have problems!

public class LoadDriver {
    public static void main(String[] args) {
        try {
            // The newInstance() call is a work around for some
            // broken Java implementations

            Class.forName("com.mysql.jdbc.Driver").newInstance();
        } catch (Exception ex) { // mostly ClassNotFoundException
            // handle the error
        }
    }
}
```

Loading the MySQL driver

```
import java.sql.Connection;
import java.sql.DriverManager;
import java.sql.SQLException;
```

```
// Notice, do
```

```
public class L
    public sta
```

```
    try {
```

```
        //
```

```
        //
```

```
        Cl
```

```
    } catch (Exception ex) { // mostly ClassNotFoundException
        // handle the error
```

```
    }
```

```
}
```

Note: in recent versions of the Java JVM, this step is no longer needed.

The class is looked up in all the libraries (.jar) found in the CLASSPATH

ve problems!

or some

stance());

2. Define the connection URL

- ▶ **The Driver Manager needs some information to connect to the DBMS**
 - ▶ The database type (to call the proper Driver, that we already loaded in the first step)
 - ▶ The server address
 - ▶ Authentication information (user/pass)
 - ▶ Database / schema to connect to
- ▶ **All these parameters are encoded into a string**
 - ▶ The exact format depends on the Driver vendor

MySQL Connection URL format

- ▶ `jdbc:mysql://[host:port],[host:port].../[database][?propertyName1][=propertyValue1][&propertyName2][=propertyValue2]...`
- ▶ `jdbc:mysql://`
- ▶ `host:port` (`localhost`)
- ▶ `/database`
- ▶ `?user=username`
- ▶ `&password=pppppppp`

3. Establish the connection

- ▶ Use `DriverManager.getConnection`
 - ▶ Uses the appropriate driver according to the connection URL
 - ▶ Returns a `Connection` object
- ▶ `Connection connection = DriverManager.getConnection(URLString)`
- ▶ Contacts DBMS, validates user and selects the database
- ▶ On the `Connection` object subsequent commands will execute queries

Example

```
import java.sql.Connection;
import java.sql.DriverManager;
import java.sql.SQLException;

    try {
        Connection conn = DriverManager.getConnection(
"jdbc:mysql://localhost/test?user=monty&password=secret");

        // Do something with the Connection
        ....

    } catch (SQLException ex) {
        // handle any errors
        System.out.println("SQLException: " + ex.getMessage());
        System.out.println("SQLState: " + ex.getSQLState());
        System.out.println("VendorError: " + ex.getErrorCode());
    }
```

Class diagram

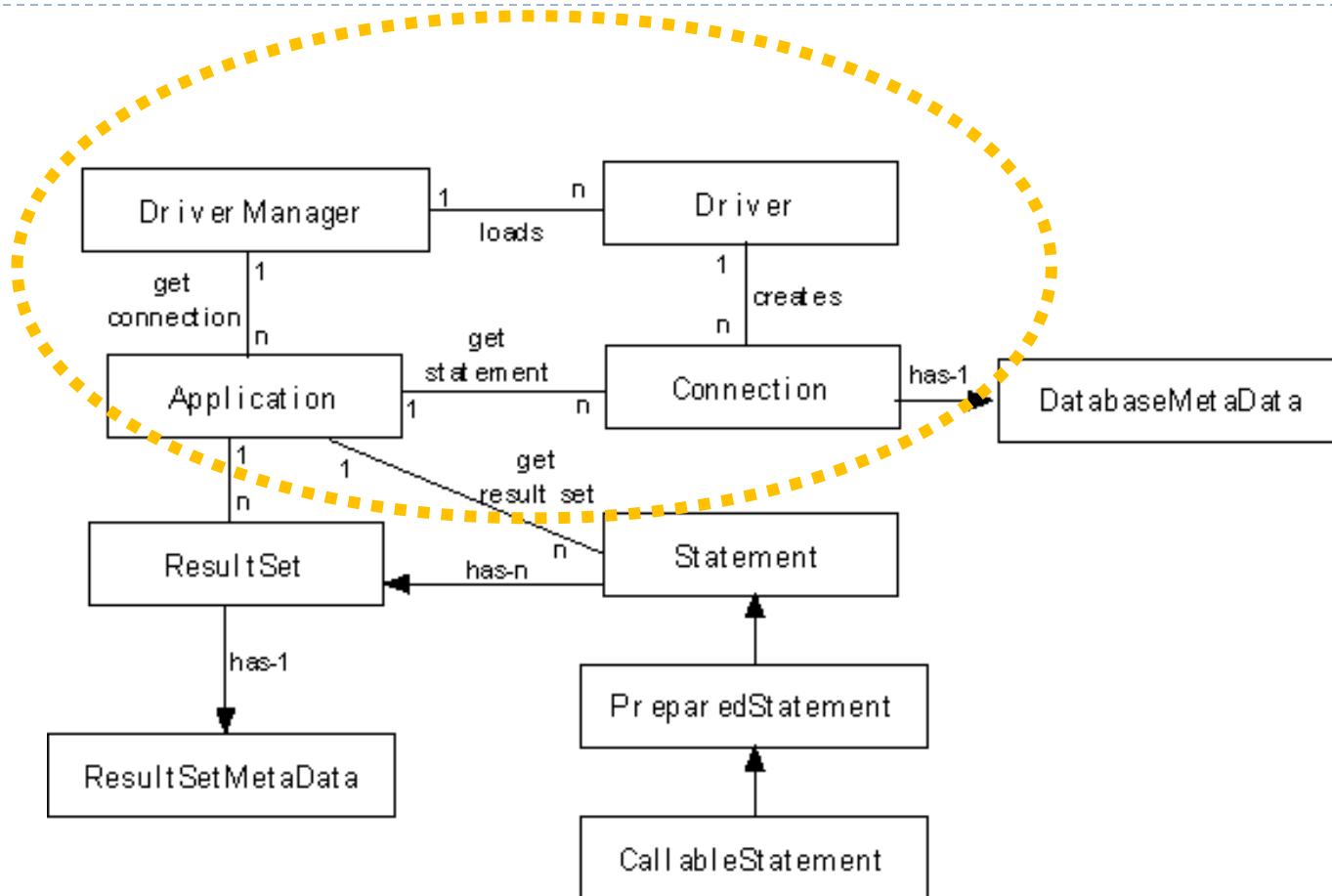

4. Create a Statement object

- ▶ `Statement statement = connection.createStatement() ;`
- ▶ Creates a Statement object for sending SQL statements to the database.
- ▶ SQL statements without parameters are normally executed using Statement objects.

- ▶ For efficiency and security reasons, we will always use a `PreparedStatement` object (see later...).

5. Execute a query

- ▶ Use the `executeQuery` method of the `Statement` class
 - ▶ `ResultSet executeQuery(String sql)`
 - ▶ `sql` contains a `SELECT` statement
- ▶ Returns a `ResultSet` object, that will be used to retrieve the query results

Class diagram

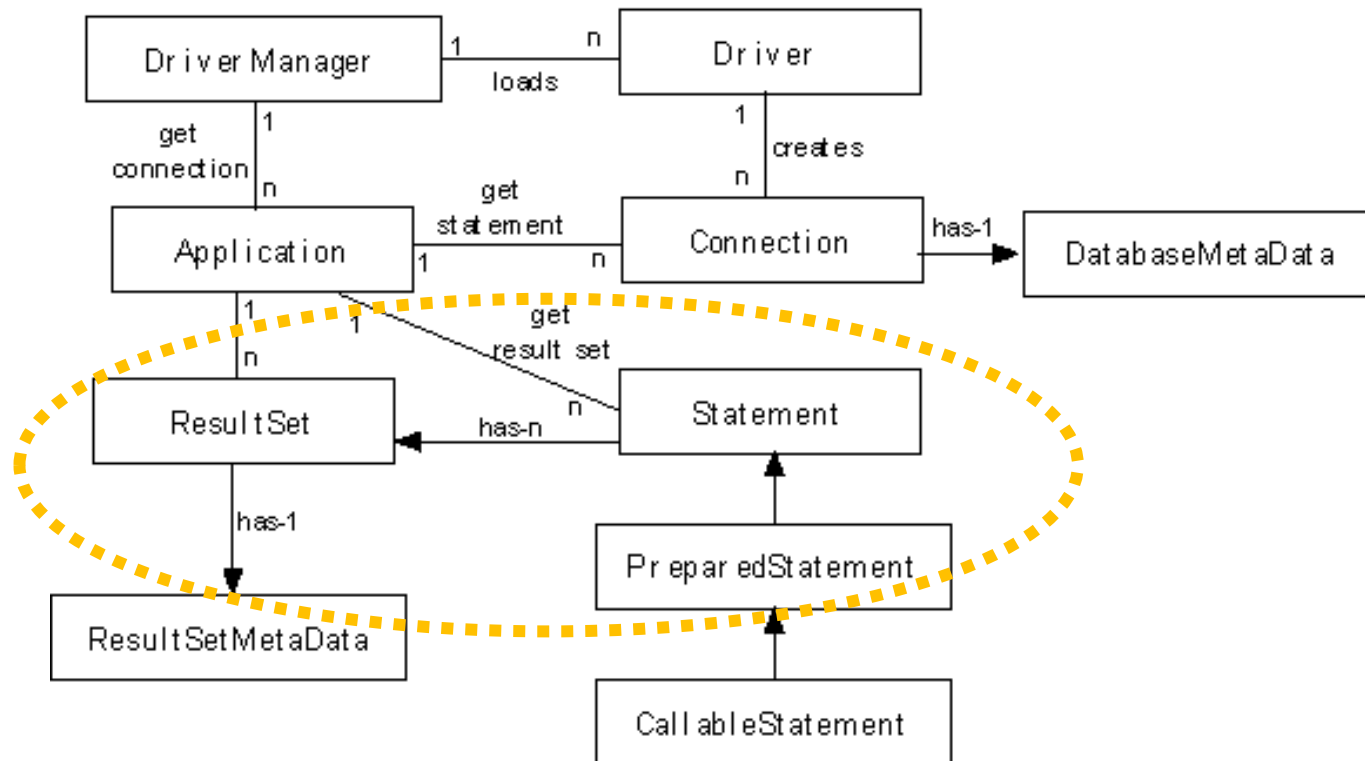

Other execute methods

- ▶ `int executeUpdate(String sql)`
 - ▶ For INSERT, UPDATE, or DELETE statements
 - ▶ For other SQL statements that don't return a resultset (e.g., CREATE TABLE)
 - ▶ returns either the row count for INSERT, UPDATE or DELETE statements, or 0 for SQL statements that return nothing

- ▶ `boolean execute(String sql)`
 - ▶ For general SQL statements

Example

```
String query = "SELECT col1, col2, col3 FROM  
sometable" ;
```

```
ResultSet resultSet =  
statement.executeQuery(query) ;
```

6. Process the result

- ▶ The ResultSet object *implements a “cursor”* over the query results
 - ▶ Data are available a row at a time
 - ▶ Method `ResultSet.next()` goes to the next row
 - ▶ The column values (for the selected row) are available through **getXXX** methods
 - ▶ `getInt`, `getString`, ...
 - ▶ Data types are converted from SQL types to Java types

Cursor

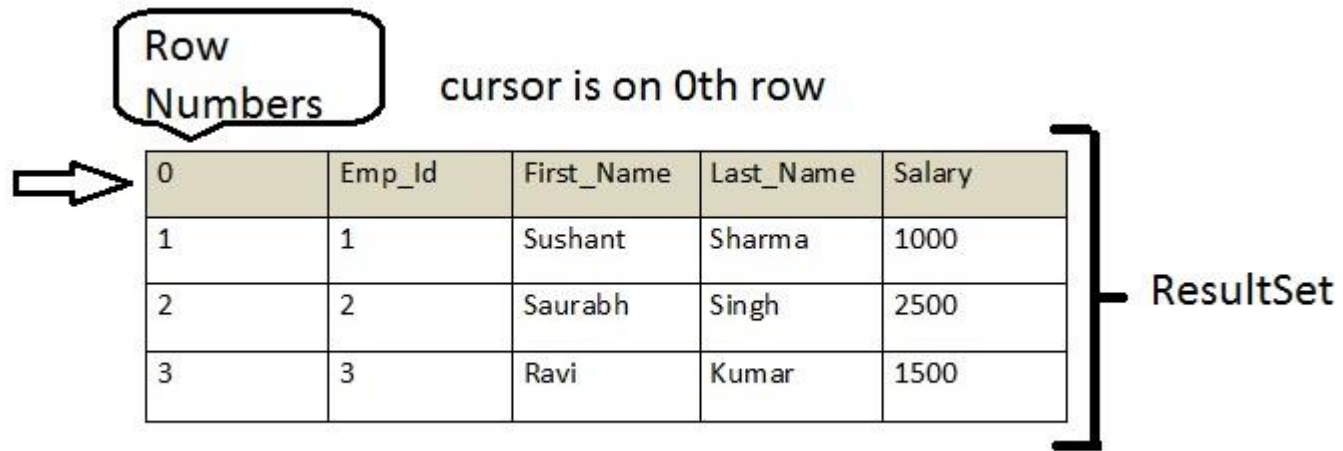

ResultSet.getXXX methods

- ▶ **XXX is the desired datatype**
 - ▶ Must be compatible with the column type
 - ▶ String is almost always acceptable
- ▶ **Two versions**
 - ▶ `getXXX(int columnIndex)`
 - ▶ number of column to retrieve (starting from 1 – beware!)
 - ▶ `getXXX(String columnName)`
 - ▶ name of column to retrieve
 - ▶ Always preferred

ResultSet navigation methods

- ▶ `boolean next()`
 - ▶ Moves the cursor down one row from its current position.
 - ▶ A `ResultSet` cursor is initially positioned **before the first row**:
 - ▶ the first call to the method `next` makes the first row the current row
 - ▶ the second call makes the second row the current row, ...

Other navigation methods (1 / 2)

- ▶ **Query cursor position**
 - ▶ `boolean isFirst()`
 - ▶ `boolean isLast()`
 - ▶ `boolean isBeforeFirst()`
 - ▶ `boolean isAfterLast()`

Other navigation methods (2/2)

▶ Move cursor

- ▶ `void beforeFirst()`
- ▶ `void afterLast()`
- ▶ `boolean first()`
- ▶ `boolean last()`
- ▶ `boolean absolute(int row)`
- ▶ `boolean relative(int rows) // positive or negative offset`
- ▶ `boolean previous()`

Example

```
while( resultSet.next() )
{
    out.println( "<p>" +
        resultSet.getString(1) + " - " +
        resultSet.getString(2) + " - " +
        resultSet.getString(3) + "</p>" ) ;
}
```

Datatype conversions (MySQL)

These MySQL Data Types	Can always be converted to these Java types
CHAR, VARCHAR, BLOB, TEXT, ENUM, and SET	<code>java.lang.String</code> , <code>java.io.InputStream</code> , <code>java.io.Reader</code> , <code>java.sql.Blob</code> , <code>java.sql.Clob</code>
FLOAT, REAL, DOUBLE PRECISION, NUMERIC, DECIMAL, TINYINT, SMALLINT, MEDIUMINT, INTEGER, BIGINT	<code>java.lang.String</code> , <code>java.lang.Short</code> , <code>java.lang.Integer</code> , <code>java.lang.Long</code> , <code>java.lang.Double</code> , <code>java.math.BigDecimal</code>
DATE, TIME, DATETIME, TIMESTAMP	<code>java.lang.String</code> , <code>java.sql.Date</code> , <code>java.sql.Timestamp</code>

Datatype conversions

	TINYINT	SMALLINT	INTEGER	BIGINT	REAL	FLOAT	DOUBLE	DECIMAL	NUMERIC	BIT	CHAR	VARCHAR	LONGVARCHAR	BINARY	VARBINARY	LONGVARBINARY	DATE	TIME	TIMESTAMP	CLOB	BLOB	ARRAY	REF	STRUCT	JAVA OBJECT
getBytes	X	x	x	x	x	x	x	x	x	x	x	x	x												
getShort	x	X	x	x	x	x	x	x	x	x	x	x	x												
getInt	x	x	X	x	x	x	x	x	x	x	x	x	x												
getLong	x	x	x	X	x	x	x	x	x	x	x	x	x												
getFloat	x	x	x	x	X	x	x	x	x	x	x	x	x												
getDouble	x	x	x	x	x	X	X	x	x	x	x	x	x												
getBigDecimal	x	x	x	x	x	x	X	X	x	x	x	x	x												
getBoolean	x	x	x	x	x	x	x	x	x	X	x	x	x												
getString	x	x	x	x	x	x	x	x	x	x	X	X	x	x	x	x	x	x	x						
getBytes														X	X	x									
getDate											x	x	x				X	x							
getTime											x	x	x					X	x						
getTimestamp											x	x	x				x	x	X						
getAsciiStream											x	x	X	x	x	x									
getUnicodeStream											x	x	X	x	x	x									
getBinaryStream														x	x	X									
getClob																				X					
getBlob																					X				
getArray																						X			
getRef																							X		
getCharacterStream											x	x	X	x	x	x									
getObject	x	x	x	x	x	x	x	x	x	x	x	x	x	x	x	x	x	x	x	x	x	x	x	X	X

Table 5.1: Use of ResultSet.getXXX Methods to Retrieve JDBC Types

7. Close the connection

- ▶ **Additional queries may be done on the same connection.**
 - ▶ Each returns a different `ResultSet` object, unless you re-use it
 - ▶ When no longer needed, `ResultSet` resources can be freed by 'closing' it: `resultSet.close()`
- ▶ **When no additional queries are needed, close the connection to the database:**
 - ▶ `connection.close() ;`

What's wrong with statements?

- ▶ `String user = txtUserName.getText() ; // JavaFX`
- ▶ `String user = request.getParameter("username") ; // JSP`
- ▶ `String sql = "select * from users where username='" + user + "'" ;`
- ▶ **Problems:**
 - ▶ Security
 - ▶ Performance

Security risk

- ▶ SQL injection – syntax errors or privilege escalation

- ▶ Example

- ▶ Username : `' ; delete * from users ; --`



```
select * from users where  
username=''; delete * from  
users ; -- '
```

- ▶ **Must** detect or escape all dangerous characters!
 - ▶ Will **never** be perfect...
- ▶ **Never** trust user-entered data. Never. Not once. Really.

SQL injection attempt 😊



SQL injection attempt 😊

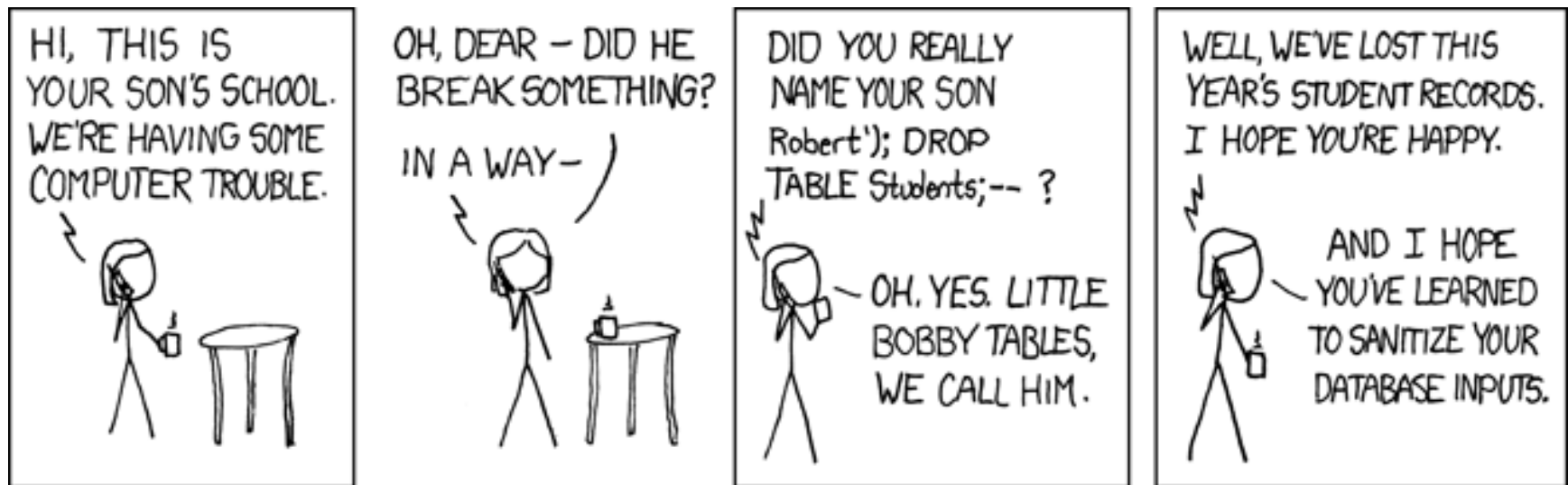

<http://xkcd.com/327/>

Performance limitations

- ▶ **Performance limit**
 - ▶ Query must be re-parsed and re-optimized every time
 - ▶ Complex queries require significant set-up overhead
- ▶ **When the same query is repeated (even with different data), parsing and optimization wastes CPU time in the DBMS server**
 - ▶ Increased response-time latency
 - ▶ Decreased scalability of the system

Prepared statements

- ▶ Separate statement **creation** from statement **execution**
 - ▶ At creation time: define SQL syntax (**template**), with placeholders for variable quantities (**parameters**)
 - ▶ At execution time: define actual quantities for placeholders (**parameter values**), and run the statement
- ▶ Prepared statements can be re-run many times
- ▶ Parameter values are automatically
 - ▶ Converted according to their Java type
 - ▶ Escaped, if they contain dangerous characters
 - ▶ Handle non-character data (serialization)

Example

```
Connection connection =  
DriverManager.getConnection(url, username, password);
```

```
String template =  
"UPDATE music SET price = ? WHERE id = ?";
```

```
PreparedStatement statement =  
connection.prepareStatement(template);
```

```
float[] newPrices = getNewPrices();  
int[] recordingIDs = getIDs();
```

```
for(int i=0; i<recordingIDs.length; i++) {  
    statement.setFloat(1, newPrices[i]); // Price  
    statement.setInt(2, recordingIDs[i]); // ID  
  
    statement.execute();  
}
```

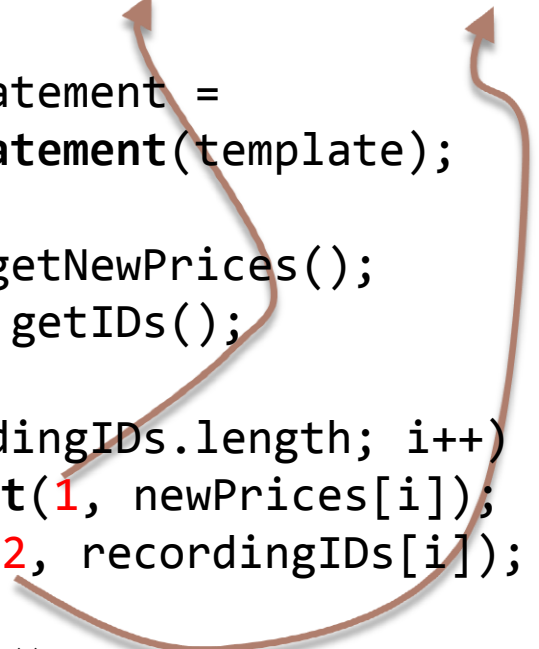

Prepared statements

- ▶ **Easier to write**
 - ▶ Data type conversion done by JDBC library
- ▶ **Secure (no SQL injection possible)**
 - ▶ Quoting is done by JDBC library
- ▶ **More efficient**
 - ▶ Query re-use
 - ▶ Parameter values sent in binary form
- ▶ **The bottom line: *Always use prepared statements.***

Callable statements

- ▶ Many DBMSs allow defining “stored procedures”, directly defined at the DB level
- ▶ Stored procedures are SQL queries (with parameters), or sequences of queries
 - ▶ Language for defining stored procedures is DBMS-dependent: not portable!
- ▶ MySQL: <http://dev.mysql.com/doc/refman/5.5/en/stored-programs-views.html> (chapter 18)
- ▶ Calling stored procedures: use CallableStatement in JDBC
 - ▶ Example: <http://dev.mysql.com/doc/refman/5.5/en/connector-j-usagenotes-basic.html#connector-j-examples-stored-procedure>

Problems

- ▶ Database code involves a lot of «specific» knowledge
 - ▶ Connection parameters
 - ▶ SQL commands
 - ▶ The structure of the database
- ▶ Bad practice to «mix» this low-level information with main application code
 - ▶ Reduces portability and maintainability
 - ▶ Creates more complex code
 - ▶ Breaks the «one-class one-task» assumption
- ▶ What is a better code organization?

Goals

- ▶ Encapsulate DataBase access into separate classes, distinct from application ones
 - ▶ All other classes should be shielded from DB details
- ▶ DataBase access should be independent from application needs
 - ▶ Potentially reusable in different parts of the application
- ▶ Develop a reusable development patterns that can be easily applied to different situations

Data Access Object (DAO) – 1 / 2

- ▶ **«Client» classes:**
 - ▶ Application code that needs to access the database
 - ▶ Ignorant of database details (connection, queries, schema, ...)
- ▶ **«DAO» classes:**
 - ▶ Encapsulate all database access code (JDBC)
 - ▶ The only ones that will ever contact the database
 - ▶ Ignorant of the goal of the Client

Data Access Object (DAO) – 2/2

- ▶ Low-level database classes: DriverManager, DataSource, ResultSet, etc
 - ▶ Used by DAO (only!) but invisible to Client
- ▶ «Transfer Object» (TO) or «Data Transfer Object» (DTO) classes
 - ▶ Contain data sent from Client to Dao and/or returned by DAO to Client
 - ▶ Represent the data model, as seen by the application
 - ▶ Usually POJO or JavaBean
 - ▶ Ignorant of DAO, ignorant of database, ignorant of Client

DAO class diagram

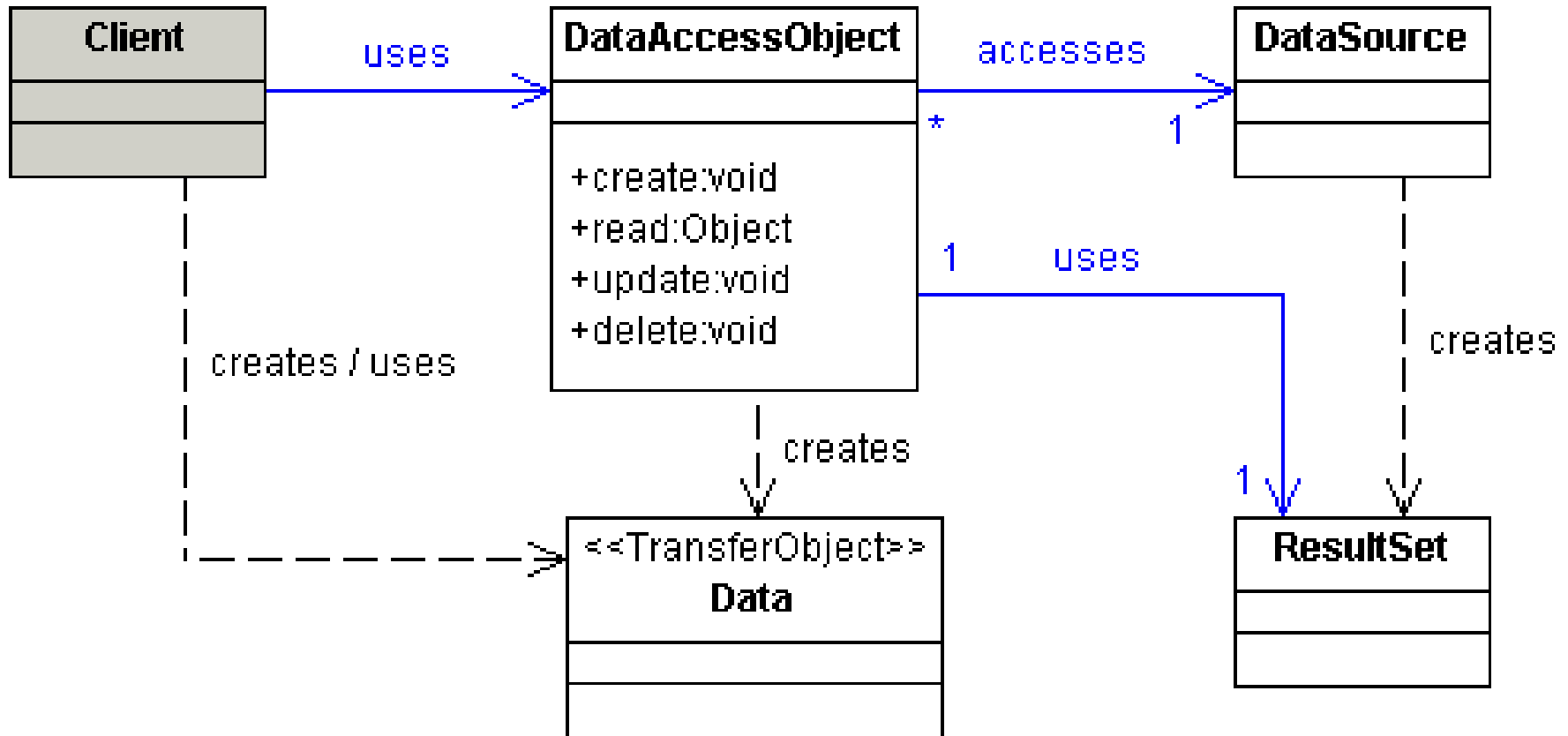

DAO Sequence diagram

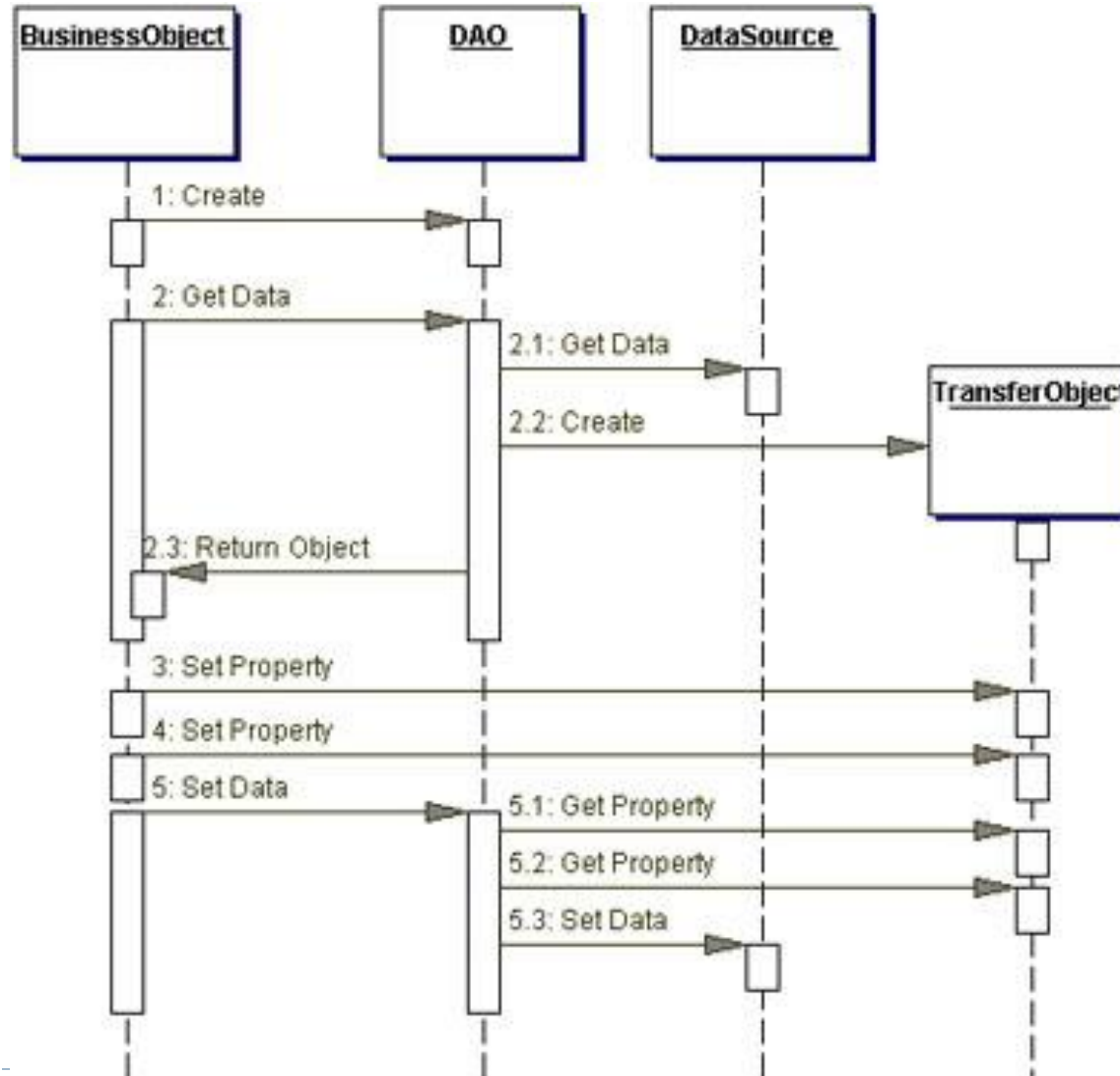

DAO design criteria

- ▶ **DAO has no state**
 - ▶ No instance variables (except Connection - maybe)
- ▶ **DAO manages one 'kind' of data**
 - ▶ Uses a small number of DTO classes and interacts with a small number of DB tables
 - ▶ If you need more, create many DAO classes
- ▶ **DAO offers CRUD methods**
 - ▶ Create, Read, Update, Delete
- ▶ **DAO may offer search methods**
 - ▶ Returning collections of DTO

public interface/class UserDao

- ▶ `public User find(Long id)`
 - ▶ `public boolean find(Long id, User u)`
 - ▶ `public boolean find(User u) // uses u.id`
- ▶ `public User find(String email, String password)`
- ▶ `public List<User> list()`
- ▶ `List<User> searchUserByName(String name)`
 - ▶ `List<User> searchByName(User u) ; // only u.name matters`

public interface/class UserDao

- ▶ `public void create(User user)`
 - ▶ `public Long create(User user) // returns new ID`
- ▶ `public void update(User user) // modify all except ID`
- ▶ `public void delete(User user)`
- ▶ `public boolean existEmail(String email)`
- ▶ `public void changePassword(User user)`

Connection pooling

- ▶ **Opening and closing DB connection is expensive**
 - ▶ Requires setting up TCP/IP connection, checking authorization, ...
 - ▶ After just 1-2 queries, the connection is dropped and all partial results are lost in the DBMS
- ▶ **Connection pool**
 - ▶ A set of “already open” database connections
 - ▶ DAO methods “lend” a connection for a short period, running queries
 - ▶ The connection is then returned to the pool (not closed!) and is ready for the next DAO needing it

JDBC 3.0 Connection pooling architecture

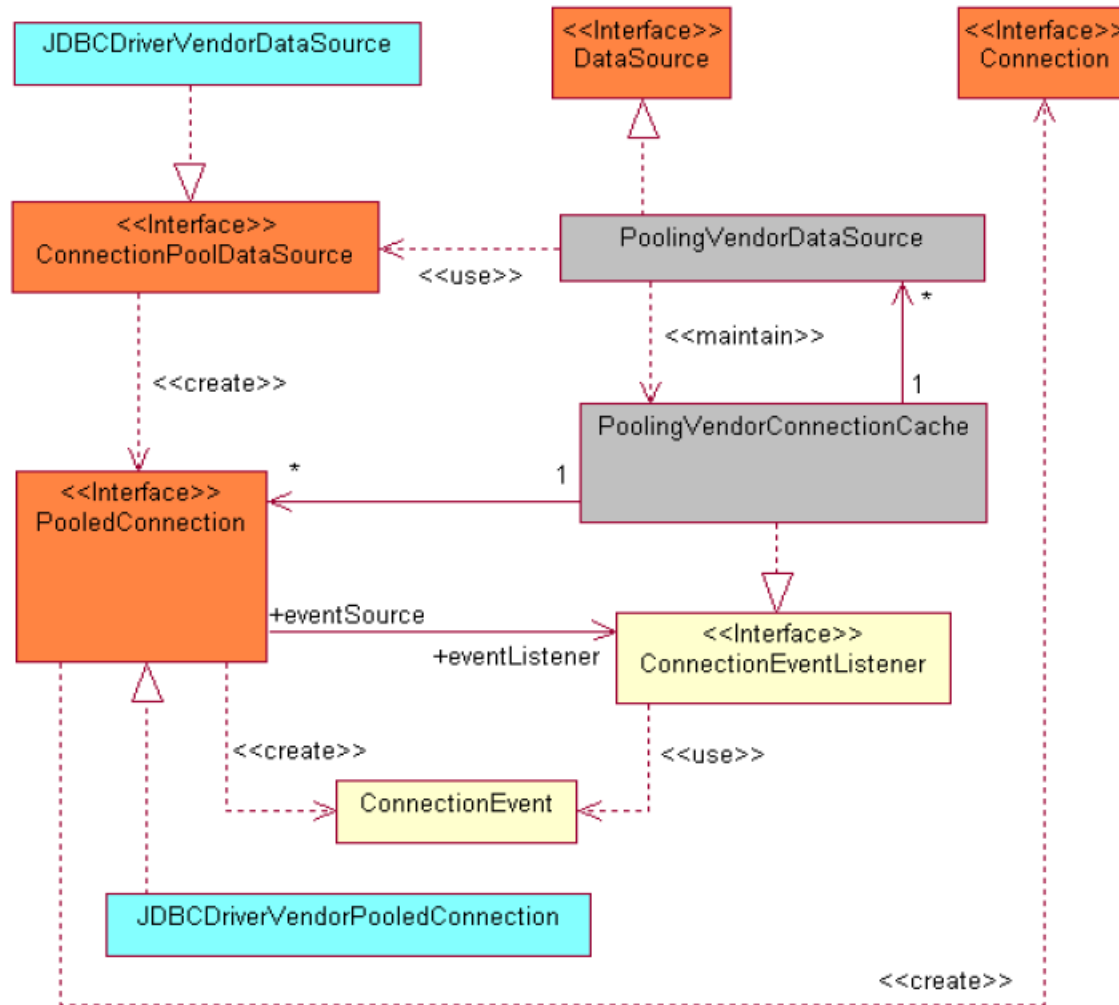

Benchmarks

	100 iterations	100 iterations	1000 iterations	3000 iterations
Pooling	547 ms	<10 ms	47 ms	31 ms ¹
Non-Pooling	4859 ms	4453 ms	43625 ms	134375 ms

The first time, the connections must be created

Second time, reuse connections

Negligible overhead

10x slower

No improvement

Linear increase



Support in J2EE and Tomcat

- ▶ **The Java EE Platform Specification requires:**
 - ▶ Java EE Application Servers must provide a *DataSource* implementation
 - ▶ DataSource is a connection pool for JDBC connections
 - ▶ Tomcat implements this specification
- ▶ **DataSource – interface `javax.sql.DataSource`**
 - ▶ Alternative to DriverManager
 - ▶ DataSource implementations can be located through JNDI (Java Naming and Directory)
 - ▶ Tomcat implements a simplified JNDI service



Configure JNDI

- ▶ Tomcat's JNDI is stored in WEB-INF/web.xml
- ▶ Define a resource to access a DataSource object, with a symbolic reference name

```
<resource-ref>
  <description>
    Resource reference to a factory for java.sql.Connection
    instances that may be used for talking to a particular
    database that is configured in the <Context> configuration
    for the web application.
  </description>

  <res-ref-name>jdbc/TestDB</res-ref-name>

  <res-type>javax.sql.DataSource</res-type>

  <res-auth>Container</res-auth>

</resource-ref>
```



Configure the connection factory

- ▶ Implementation instructions are stored in META-INF/context.xml

```
<Context ...>
  ...
  <Resource
    name="jdbc/TestDB"
    auth="Container"
    type="javax.sql.DataSource"
    maxActive="100"
    maxIdle="30"
    maxWait="10000"
    username="utente1" password="utente1"
    driverClassName="com.mysql.jdbc.Driver"
    url="jdbc:mysql://localhost:3306/nazioni?autoReconnect
      =true"
  />
  ...
</Context>
```



Get a connection from the pool

- ▶ Lookup the DataSource, then get a new connection

```
/* JNDI query to locate the DataSource object */
Context initContext = new InitialContext();

Context envContext =
(Context)initContext.lookup("java:/comp/env") ; // JNDI
standard naming root

DataSource ds = (DataSource)envContext.lookup("jdbc/TestDB");

/* Ask DataSource for a connection */
Connection conn = ds.getConnection();

... use this connection to access the database ...

conn.close() ; // return connection to the pool
```

c3p0 library for connection pooling



- ▶ Open source library for adding connection pooling capabilities to JDBC drivers
 - ▶ <http://www.mchange.com/projects/c3p0/>
- ▶ Connection Pooling
- ▶ Prepared Statement Pooling
 - ▶ Automatically caches, recognizes and re-uses previously used prepared statements

Using c3p0



```
import com.mchange.v2.c3p0.*;
```

```
...
```

```
ComboPooledDataSource cpds = new ComboPooledDataSource();
```

```
cpds.setDriverClass( "org.postgresql.Driver" );  
    //loads the jdbc driver
```

```
cpds.setJdbcUrl( "jdbc:postgresql://localhost/testdb" );
```

```
cpds.setUser("dbuser");  
cpds.setPassword("dbpassword");
```

The DataSource object:
`cpds.getConnection()`
lends a connection from the pool

Closing up



- ▶ **To release a connection to the pool:**
 - ▶ `connection.close()` ;
 - ▶ ...otherwise the pool will run out of available connections!
- ▶ **To destroy the connection pool and clean up resources:**
 - ▶ `cpds.close()`;
 - ▶ Also disconnects from database.
 - ▶ May be placed in a `stop()` method in the main JavaFX class

References

- ▶ **JDBC Basics: Tutorial**

- ▶ <http://docs.oracle.com/javase/tutorial/jdbc/TOC.html>
- ▶ <http://pdf.coreservlets.com/Accessing-Databases-JDBC.pdf>

- ▶ **JDBC reference guide**

- ▶ <http://docs.oracle.com/javase/6/docs/technotes/guides/jdbc/getstart/GettingStartedTOC.fm.html>

- ▶ **JDBC JavaDoc**

- ▶ <http://docs.oracle.com/javase/6/docs/api/java/sql/package-summary.html>
- ▶ <http://docs.oracle.com/javase/6/docs/api/javax/sql/package-summary.html>

References

▶ DAO pattern

- ▶ <http://www.oracle.com/technetwork/java/dataaccessobject-138824.html>
- ▶ <http://www.corej2eepatterns.com/Patterns2ndEd/DataAccessObject.htm>
- ▶ http://en.wikipedia.org/wiki/Data_Access_Object
- ▶ <http://balusc.blogspot.it/2008/07/dao-tutorial-data-layer.html>

References

▶ Connection pooling

▶ Introduction:

<http://www.datadirect.com/resources/jdbc/connection-pooling/index.html>

▶ with MySQL Connector/J: http://dev.mysql.com/tech-resources/articles/connection_pooling_with_connectorj.html





▶ <http://dev.mysql.com/doc/refman/5.5/en/connector-j-usagenotes-j2ee.html#connector-j-usagenotes-tomcat>

▶ Tomcat tutorial: <http://tomcat.apache.org/tomcat-5.5-doc/jndi-resources-howto.html#JDBC%20Data%20Sources>

▶ c3p0 - JDBC3 Connection and Statement Pooling: <http://www.mchange.com/projects/c3p0/>

Licenza d'uso



- ▶ Queste diapositive sono distribuite con licenza Creative Commons “Attribuzione - Non commerciale - Condividi allo stesso modo (CC BY-NC-SA)”
- ▶ Sei libero:
 - ▶ di riprodurre, distribuire, comunicare al pubblico, esporre in pubblico, rappresentare, eseguire e recitare quest'opera 
 - ▶ di modificare quest'opera 
- ▶ Alle seguenti condizioni:
 - ▶ **Attribuzione** — Devi attribuire la paternità dell'opera agli autori originali e in modo tale da non suggerire che essi avallino te o il modo in cui tu usi l'opera. 
 - ▶ **Non commerciale** — Non puoi usare quest'opera per fini commerciali. 
 - ▶ **Condividi allo stesso modo** — Se alteri o trasformi quest'opera, o se la usi per crearne un'altra, puoi distribuire l'opera risultante solo con una licenza identica o equivalente a questa. 
- ▶ <http://creativecommons.org/licenses/by-nc-sa/3.0/>